



**ZHEJIANG A-CRYSTAL**  
ELECTRONIC TECHNOLOGY CO., LTD.



Issue	June 13, 2023
Rev.	1.0
Page	9

## CRYSTAL UNIT SPECIFICATIONS

客户批准 Customer Approval

(请批准后回签一份 Please Return A Copy With Approval)

Customer	
Customer P/N	
Product	CRYSTAL RESONATORS
Spec	HC-49U/500.0K~200.000M
A-Crystal P/N	AH9 Series

Drawn	Checked	Approved
<i>caogaobang</i>	<i>tanglong</i>	<i>huangweilong</i>



**ZHEJIANG A-CRYSTAL**  
**ELECTRONIC TECHNOLOGY CO., LTD.**



## 1. ELECTRICAL SPECIFICATIONS

### 1.1 Hold Type: HC-49U

No.	Item	Symb	Electrical Specification				Remark
			Min.	Type	Max.	Units	
1	Nominal Frequency	F0	500.0K		200.00	MHz	
2	Mode of Vibration		■ Fundamental △3rd Overtone △5th Overtone				
3	Frequency Tolerance	$\Delta F/F_0$	$\pm 10$	$\pm 30$	$\pm 50$	ppm	at 25°C±3°C
4	Operating Temperature Range	T <sub>OPR</sub>	-20 -40	-	+70 +85	°C	
5	Frequency Stability	T <sub>C</sub>	$\pm 30$		$\pm 50$	ppm	
6	Storage Temperature	T <sub>STG</sub>	-40	-	+85	°C	
7	Load capacitance	CL	6~specify			pF	
8	Equivalent Series Resistance	ESR	Seepage 1			Ω	
9	Drive Level	DL	-		100	μW	
10	Insulation Resistance	IR	500	-	-	MΩ	At 100V <sub>DC</sub>
11	Shunt Capacitance	C <sub>0</sub>			7	pF	
12	Aging Per Year	F <sub>a</sub>	-5	-	+5	ppm	First Yea
13	Moist are Sensitivity Level	MSL		1			J-STD-033
14	Package type	13.46*11.05*4.65					

#### Seepage1

Frequency Range	Mode of Vibration	ESR (Ω) Max
0. 500MHz≤F0<1. 8432MHz	Fund	<3000
1. 8432MHz≤F0<3.000MHz	Fund	<500
3. 100MHz≤F0<4. 900MHz	Fund	<100
5. 000MHz≤F0<12. 000MHz	Fund	<40
12. 10MHz≤F0<40. 000MHz	Fund	<30
20. 100MHz≤F0<100. 000MHz	3rd OT	<40
100. 100MHz≤F0<150. 000MHz	5rd OT	<80
150. 100MHz≤F0≤200. 000MHz	7th OT	<100



### 1.2 Dimension (Unit: mm)

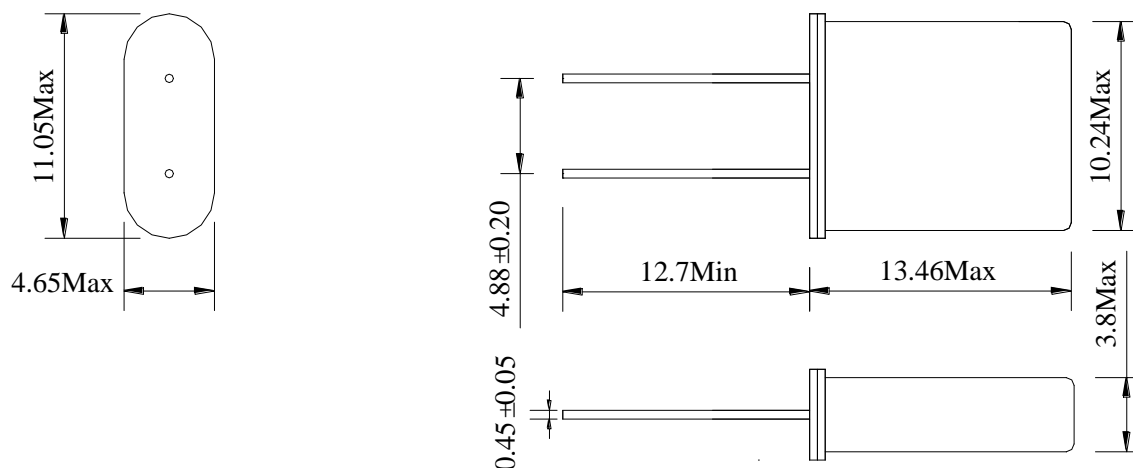

### 1.3 The soldering requirements

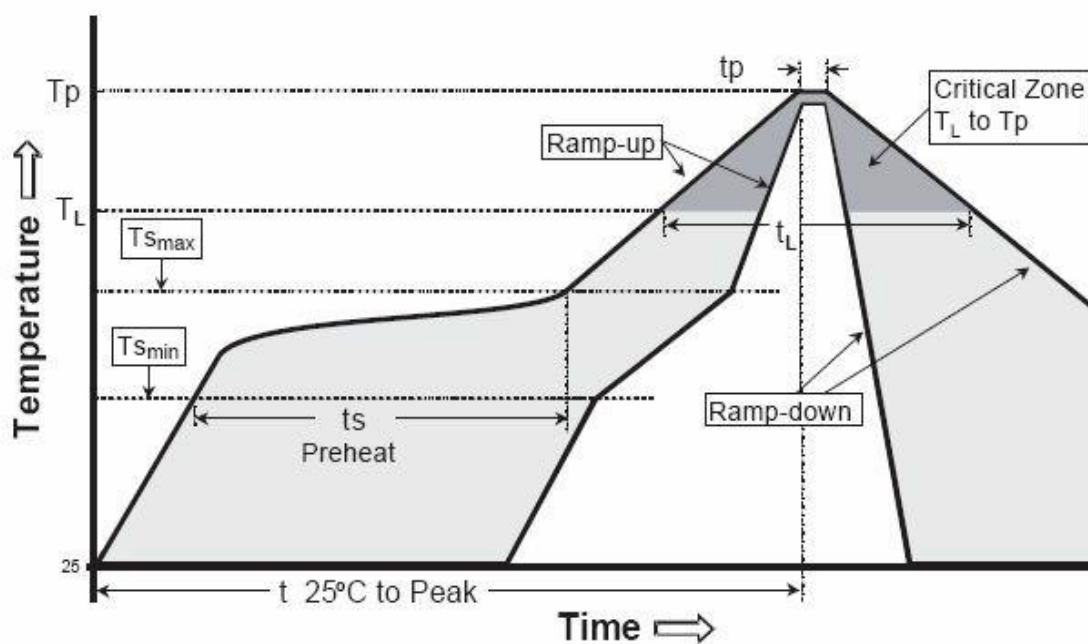

$T_s = 180^\circ\text{C}/70 \sim 100\text{sec}$ ,  $T_L = 240^\circ\text{C}/20 \sim 50\text{sec}$ ,  $T_p = 250^\circ\text{C}/7 \sim 8\text{sec}$



**ZHEJIANG A-CRYSTAL**  
**ELECTRONIC TECHNOLOGY CO., LTD.**



## 2. PACKING

### 2.1 Section of package

Package is made of corrugated paper with thickness of 0.8cm. Package has 10 inner boxes, each box has 10 bag

#### 2.1.1 Quantity of package

Each bag 100 pieces of Crystal Resonators

Per inner box 10 bag ( 0.2k/bag )

Per package 10 inner boxes & 10 inner boxes

(10000 pieces of Crystal Resonators)

#### 2.1.2 Inner Box Dimensions (Unit: mm)

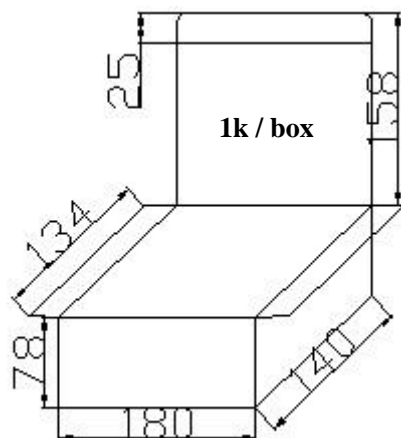

#### 2.1.3 Dimensions and Mark (Unit: mm)

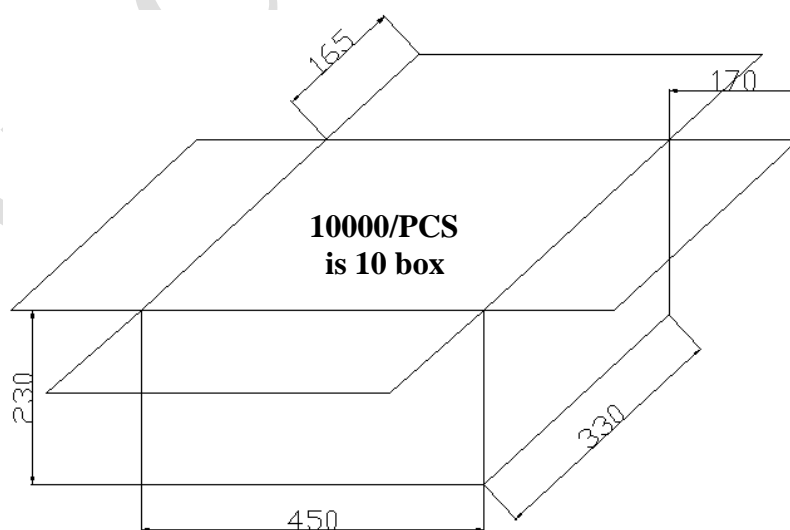



ZHEJIANG A-CRYSTAL

ELECTRONIC TECHNOLOGY CO., LTD.



### 3. Products Code

#### 3.1 DIP Crystal Resonators/MHz

公司代码 浙江一晶	产品型号 (2位)	工作频率 (全频点位数)	负载电容 (1位字母)	调整频差 (1位字母)	温度频差 (1位字母)	工作温度 (1位字母)	其它
A-crystal Logo	Package	Nominal Frequency	Load Capacitance	Frequency Tolerating	Freq Temp Characteristics	Operating Temperture Range	Others
A	H9 (HC-49U)	8.000M	A = 12.5PF	01=5PPM	A=10PPM	1=0~50	Special
		12.000M	B = 10PF	02=10PPM	B=15PPM	2=-10~60	
			C = 9PF	03=20PPM	C=20PPM	3=-10~70	
			D = 8PF	04=30PPM	D=25PPM	4=-20~70	
			E = 7PF	05=40PPM	E=30PPM	5=-30~85	
			F = 6PF	06=50PPM	F=50PPM	6=-40~85	
			G = 16PF	07=100PPM	G=100PPM	7=-40~105	
			H = 18PF			8=-40~125	
			J = 20PF				
			K = 22PF				
			L = 30PF				