



ZHEJIANG A-CRYSTAL
ELECTRONIC TECHNOLOGY CO., LTD.



Issue	June 13, 2023
Rev.	1.0
Page	9

CRYSTAL UNIT SPECIFICATIONS

客户批准 Customer Approval

(请批准后回签一份 Please Return A Copy With Approval)

Customer	
Customer P/N	
Product	CRYSTAL RESONATORS
Spec	HC-49SB/3.072~100.000M
A-Crystal P/N	AHV Series

Drawn	Checked	Approved
<i>caogaobang</i>	<i>tanglong</i>	<i>huangweilong</i>



ZHEJIANG A-CRYSTAL
ELECTRONIC TECHNOLOGY CO., LTD.



1. ELECTRICAL SPECIFICATIONS

1.1 Hold Type: HC-49SB

No.	Item	Symb	Electrical Specification				Remark
			Min.	Type	Max.	Units	
1	Nominal Frequency	F0	3.072		100.00	MHz	
2	Mode of Vibration		■ Fundamental △3rd Overtone △5th Overtone				
3	Frequency Tolerance	$\Delta F/F_0$	± 10	± 30	± 50	ppm	at 25°C±3°C
4	Operating Temperature Range	T _{OPR}	-20 -40	-	+70 +85	°C	
5	Frequency Stability	T _C	± 30		± 50	ppm	
6	Storage Temperature	T _{STG}	-40	-	+85	°C	
7	Load capacitance	CL	6~specify			pF	
8	Equivalent Series Resistance	ESR	Seepage 1			Ω	
9	Drive Level	DL	-		100	μW	
10	Insulation Resistance	IR	500	-	-	MΩ	At 100V _{DC}
11	Shunt Capacitance	C ₀			7	pF	
12	Aging Per Year	F _a	-5	-	+5	ppm	First Yea
13	Moist are Sensitivity Level	MSL		1			J-STD-033
14	Package type	12.7*5.0*5.2					

Seepage1

Frequency Range	Mode of Vibration	ESR (Ω) Max
3.000MHz≤F0<4.000MHz	Fund	<200
4.100MHz≤F0<6.000MHz	Fund	<80
6.100MHz≤F0<8.000MHz	Fund	<50
8.100MHz≤F0<16.000MHz	Fund	<40
16.10MHz≤F0<48.000MHz	Fund	<30
24.100MHz≤F0<40.000MHz	3rd OT	<100
40.100MHz≤F0<80.000MHz	3rd OT	<50
50.000MHz≤F0≤100.000MHz	5th OT	<100



ZHEJIANG A-CRYSTAL
ELECTRONIC TECHNOLOGY CO., LTD.



1.2 Dimension (Unit: mm)

GENERAL TOLERANCE : ± 0.10

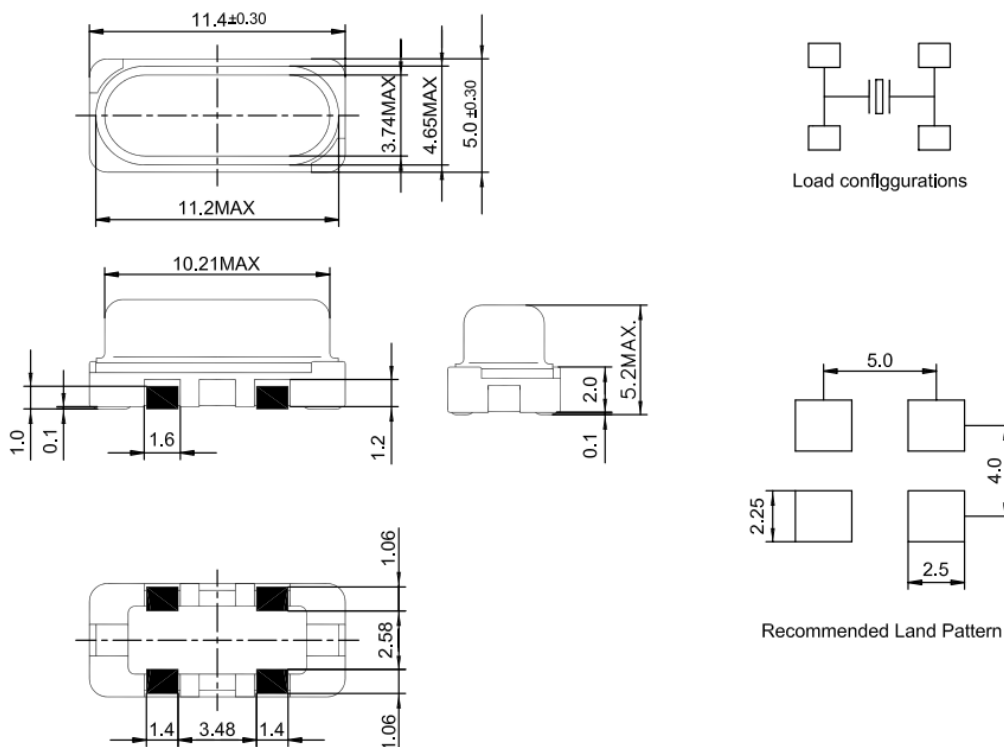

1.3 The soldering requirements

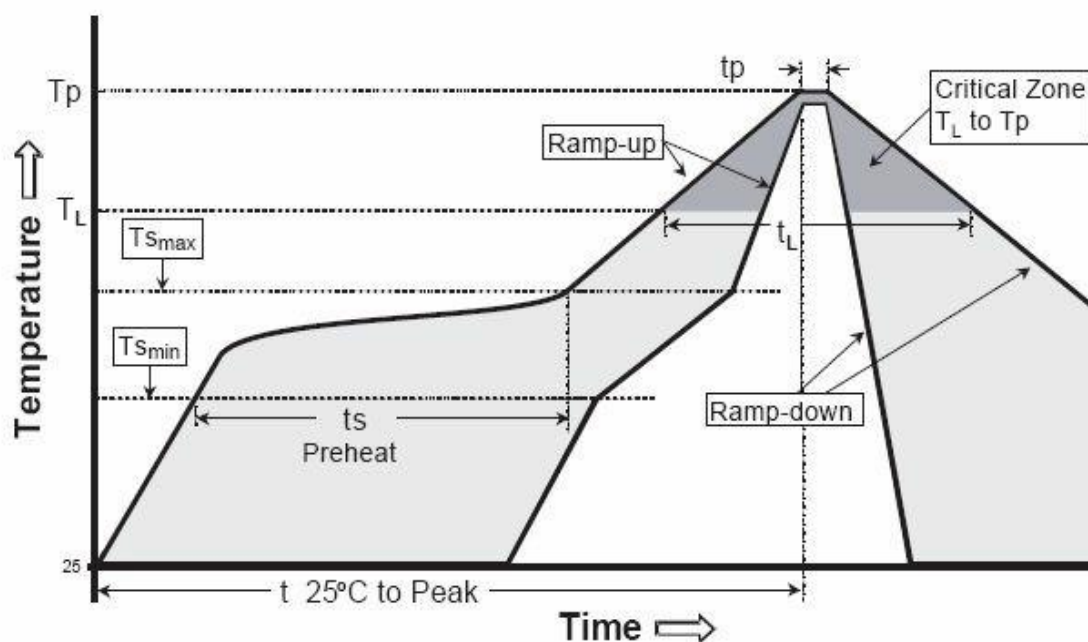

$T_s = 180^\circ\text{C} / 70 \sim 100\text{sec}$, $T_L = 240^\circ\text{C} / 20 \sim 50\text{sec}$, $T_p = 250^\circ\text{C} / 7 \sim 8\text{sec}$



2. PACKING

2.1 Packing Method Sketch Map (Unit: mm)

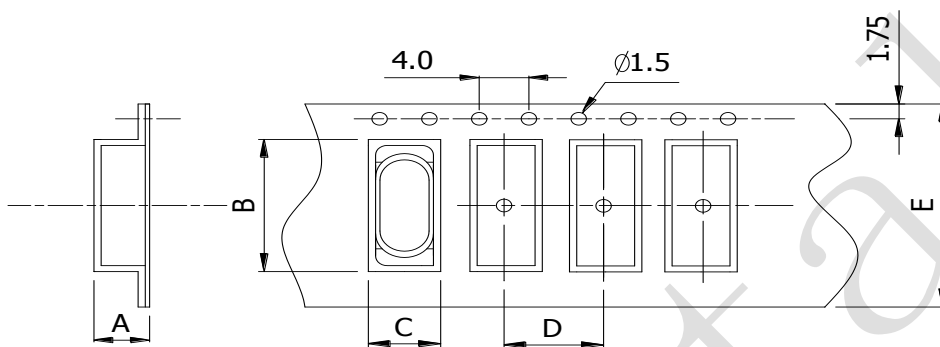

F	E	D	C	B	A
0.40 ± 0.05	24.00 ± 0.30	12.00 ± 0.10	5.00 ± 0.10	14.2 ± 0.20	4.40 ± 0.10

2.2 Reel Dimensions (Unit: mm)

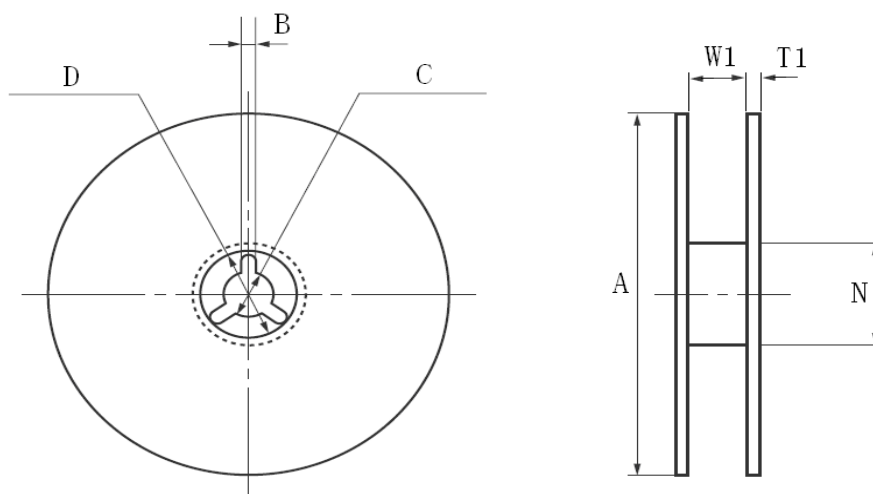

Pieces per reel: 1000/reel

A	B	C	D	N	W1	T1
$\phi 330 \pm 0.20$	2.50 ± 0.50	$\phi 13.5 \pm 0.50$	$\phi 21.0 \pm 1.00$	$\phi 99.0 \pm 1.00$	24.5 ± 1.00	2.3 ± 0.50



ZHEJIANG A-CRYSTAL

ELECTRONIC TECHNOLOGY CO., LTD.



3. Products Code

3.1 SMD Crystal Resonators/MHz

公司代码 浙江一晶	产品型号 (2位)	工作频率 (全频点位数)	负载电容 (1位字母)	调整频差 (1位字母)	温度频差 (1位字母)	工作温度 (1位字母)	其它
A-crystal Logo	Package	Nominal Frequency	Load Capacitance	Frequency Tolerating	Freq Temp Characteristics	Operating Temperture Range	Others
A	HV (HC-49SB)	8.000M	A = 12.5PF	01=5PPM	A=10PPM	1=0~50	Special
		12.000M	B = 10PF	02=10PPM	B=15PPM	2=-10~60	
			C = 9PF	03=20PPM	C=20PPM	3=-10~70	
			D = 8PF	04=30PPM	D=25PPM	4=-20~70	
			E = 7PF	05=40PPM	E=30PPM	5=-30~85	
			F = 6PF	06=50PPM	F=50PPM	6=-40~85	
			G = 16PF	07=100PPM	G=100PPM	7=-40~105	
			H = 18PF			8=-40~125	
			J = 20PF				
			K = 22PF				
			L = 30PF				