



Issue	December 21, 2024
Rev.	1.0
Page	8

CRYSTAL UNIT SPECIFICATIONS

客户批准 Customer Approval

(请批准后回签一份 Please Return A Copy With Approval)

Customer	
Customer P/N	
Product	SMD 7050 XO
Spec	POSC7050J/19.44M~320.000M
A-Crystal P/N	AOB Series

Drawn	Checked	Approved
<i>Caoqiaobang</i>	<i>Fengying</i>	<i>Tanqlong</i>



1. ELECTRICAL SPECIFICATIONS

1.1 Hold Type: POSC7050J

No.	Item	Symb	Electrical Specification				Remark
			Min.	Type	Max.	Units	
1	Nominal Frequency	F_0	19.440		320.00	MHz	
2	Frequency Stability	ST	± 25		± 100	ppm	
3	Operating Temperature Range	T_{OPR}	-20		+125	$^{\circ}\text{C}$	
4	Storage Temperature Range	T_{STG}	-55		+125	$^{\circ}\text{C}$	
5	Power supply Voltage	V_{DD}	2.5		3.3	V	$\pm 5\%$
6	Start UP Time	T_{OSC}			10	ms	To 90% of Final Amplitude
7	Output waveform		LVDS Electrical Characteristics				
8	Current Consumption	I_{CC}			60	mA	$R_L=50\Omega$ to VDD -2V
9	Standby current	I_{CC}			30	μA	OE=LOW
10	Output Voltage High	V_{OH}		1.43	1.6	V	
11	Output Voltage Low	V_{OL}	0.9	1.1		V	
12	Rise Time	T_r	0.5		1.0	ns	20% ~ 80% Output Swing
13	Time Fall	T_f	0.5		1.0	ns	80% ~ 20% Output Swing
14	Symmetry	TH/T	45	50	55	%	
15	Enable Voltage High		0.7VDD			v	Note 2, (Logic 1)
16	Enable Voltage Low				0.3VDD	v	Note 2, (Logic 0)
17	Output Enable Delay Time				2	ms	
18	Output Disable Delay Time				200	ns	
19	Output waveform		LVPECL Electrical Characteristics				
20	Current Consumption	I_{CC}			60	mA	$R_L=50\Omega$ to VDD -2V
21	Standby current	I_{CC}			30	μA	OE=LOW
22	Output Voltage High	V_{OH}	VDD-1.025		VDD-0.88	V	
23	Output Voltage Low	V_{OL}	VDD-1.81		VDD-1.62	V	



ZHEJIANG A-CRYSTAL
ELECTRONIC TECHNOLOGY CO., LTD.



24	Rise Time	Tr	0.5		1.0	ns	20% ~ 80% Output Swing
25	Time Fall	Tf	0.5		1.0	ns	80% ~ 20% Output Swing
26	Symmetry	TH/T	45	50	55	%	
27	Enable Voltage High		0.7VDD			v	Note 2, (Logic 1)
28	Enable Voltage Low				0.3VDD	v	Note 2, (Logic 0)
29	Output Enable Delay Time				2	ms	
30	Output Disable Delay Time				200	ns	
31	Output waveform	HCSL Electrical Characteristics					
32	Current Consumption	I _{CC}			40	mA	RL=50Ω to VDD -2V
33	Standby current	I _{CC}			10	uA	OE=LOW
34	Output Voltage High	V _{OH}	660	740	850	mV	
35	Output Voltage Low	V _{OL}	-150	0	150	mV	
36	Rise Time	Tr	0.5		1.0	ns	20% ~ 80% Output Swing
37	Time Fall	Tf	0.5		1.0	ns	80% ~ 20% Output Swing
38	Symmetry	TH/T	45	50	55	%	
39	Enable Voltage High		0.7VDD			v	Note 2, (Logic 1)
40	Enable Voltage Low				0.3VDD	v	Note 2, (Logic 0)
41	Output Enable Delay Time				2	ms	
42	Output Disable Delay Time				200	ns	
43	Package type	7.0*5.0*1.45					

Note 1 : Inclusive of frequency tolerance at 25°C, variation over temperature , supply voltage variation , 10 years aging and vibration.

Note 2 : Output will be enable if OE is Logic 1 or open ; Output will be disable if OE is Logic 0.

Note 3 : Phase Jitter will be slightly different according to output frequency and supply voltage.



1.2 TEST CIRCUIT(LVDS LOAD)

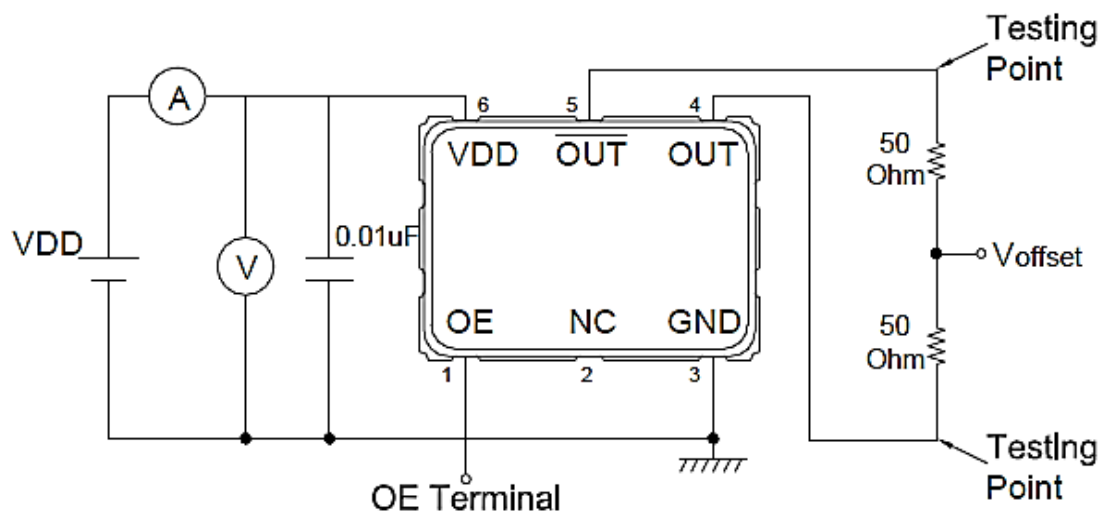

1.3 TEST CIRCUIT(LCPECL LOAD)

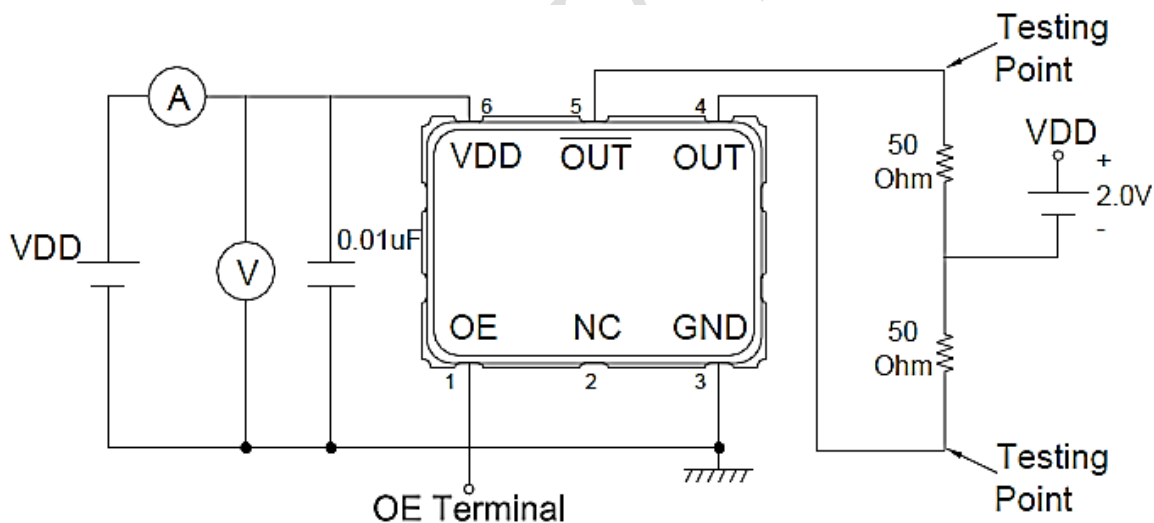



1.3 TEST CIRCUIT(HCSL LOAD)

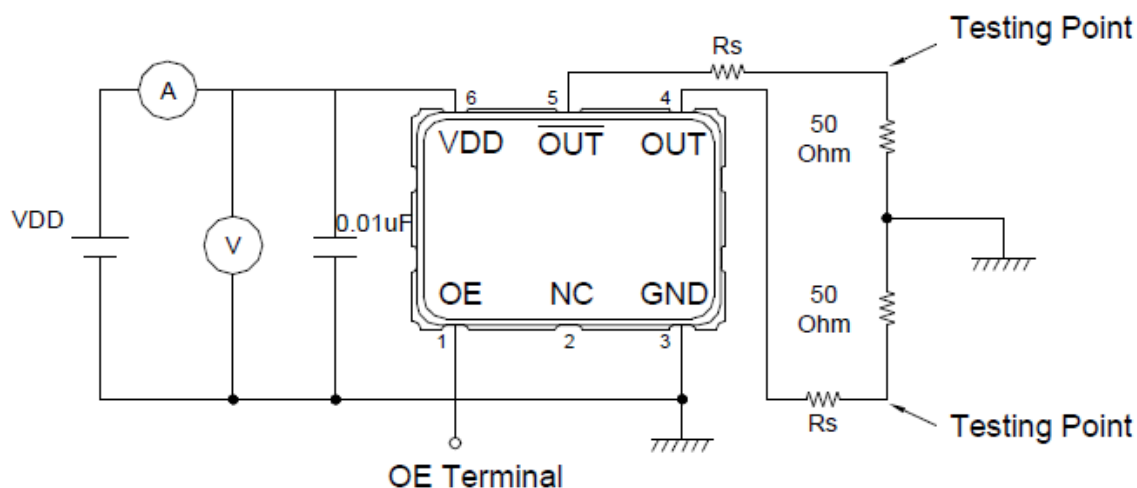

Testing Circuit Note:

1. Above testing circuits cover all the specifications except temperature test & Jitter measurement.
2. All the testing equipment are 50 Ohm terminal.
3. OE terminal is open connection except OE function test.

1.4 OUTPUT WAVFORM

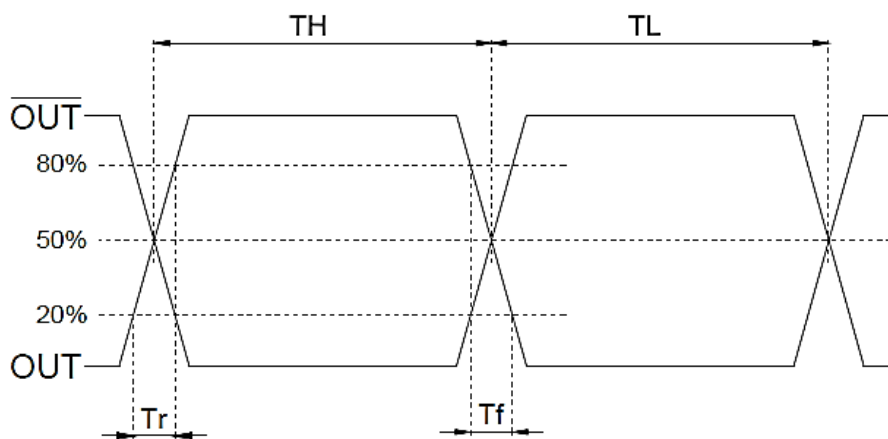



2. PRODUCT SIZE

2.1 Dimension (Unit: mm)

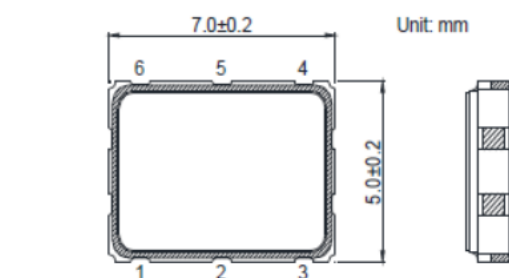

Pin Function:

1. OE
2. NC
3. GND
4. OUT
5. $\overline{\text{OUT}}$
6. VDD

Land Pattern:

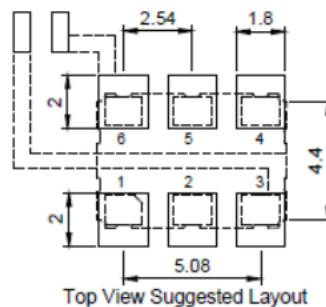
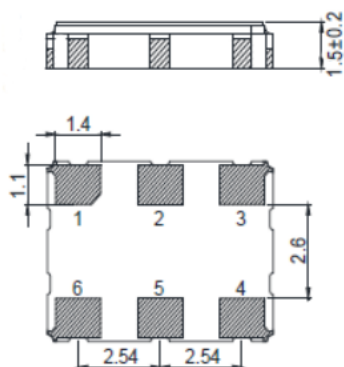

※ Pad dimension tolerance ± 0.2 mm

※ Power Supply Decoupling Capacitor is Required.

※ Pad dimension tolerance ± 0.2 mm

2.2 Marking

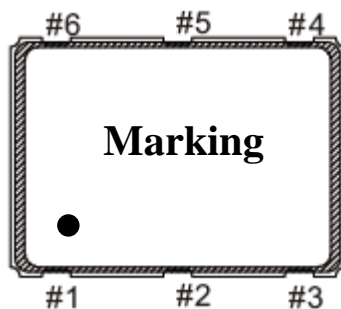



3. REFLOW PROFILES

Profiles Feature	Pb-Free Assembly
Average Ramp-up Rate (Ts max to Tp)	3°C/second max.
Preheat <ul style="list-style-type: none"> ■ Temperature Min (Ts min) ■ Temperature Max (Ts max) ■ Time (ts min to ts max) 	125°C 200°C 60~180 seconds
Time maintained above <ul style="list-style-type: none"> ■ Temperature (TL) ■ Time (tL) 	217°C 60~150 seconds
Peak/Classification Temperature (Tp)	260°C
Time within 5°C of actual Peak Temperature (tp)	10 seconds Max
Ramp-down rate	6°C/second max.
Time 25°C to Peak Temperature	8 minutes max.
Suggest reflow times	3 Times max

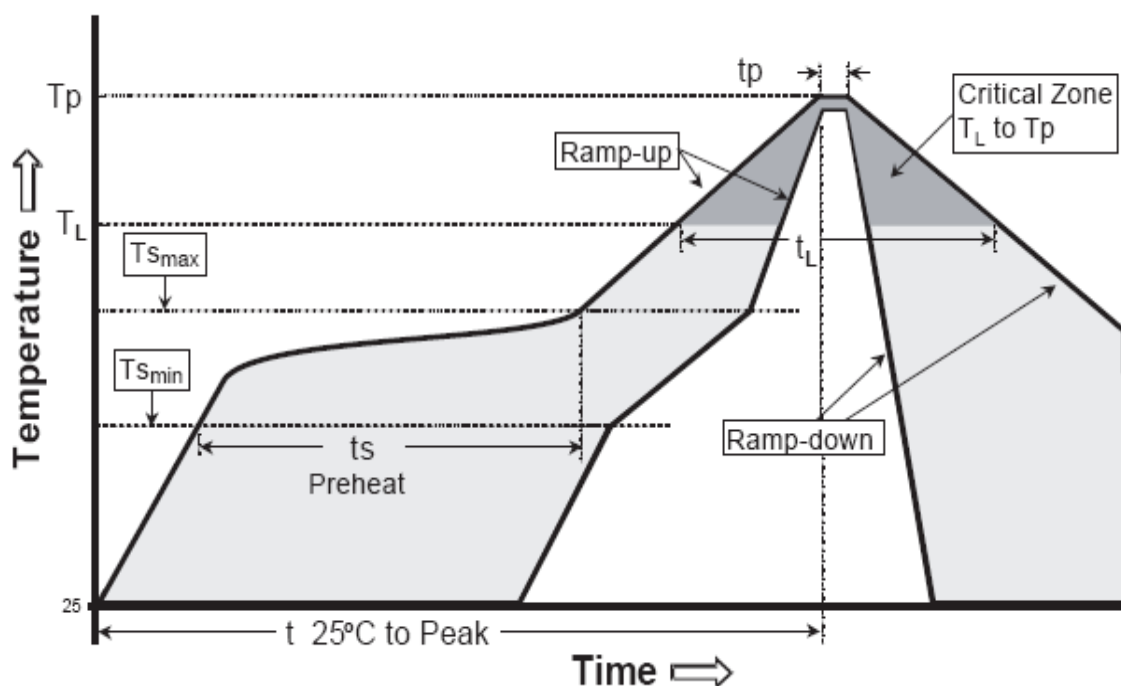

Remark: To reference JEDEC J-STD-020C



4. PACKING

4.1 Packing Method Sketch Map (Unit: mm)

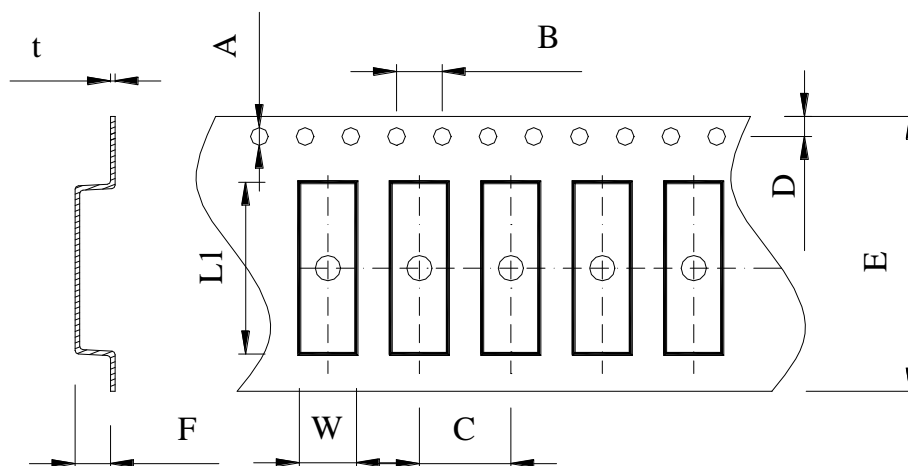

A	B	C	D	E	F	L1	W	t
1.50±0.1	4.0±0.1	4.0±0.1	1.75±0.1	16.0±0.2	1.9±0.1	7.4±0.1	5.4±0.1	0.3±0.05

4.2 Reel Dimensions (Unit: mm)

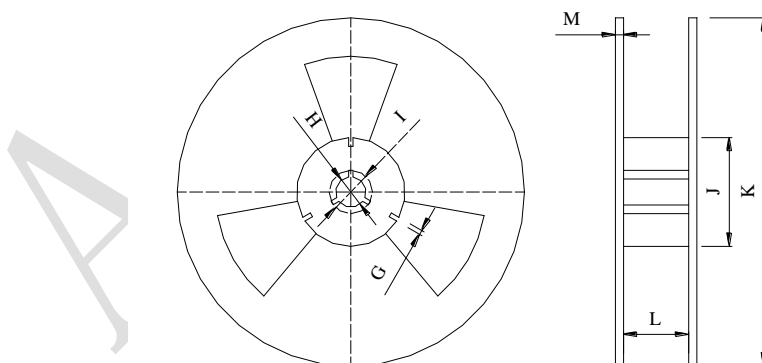

G	H	I	J	K	L	M
2.5	13.5	21.6	60.0	180	16.5	1.6

*1000pcs/Reel